

ADVANCED OXIDATION PILOT PLANTS FOR WASTEWATER & GAS TREATMENT

“CATADOX” Process

The First Step in Effluent Treatment

ESCO has developed and tested a new advanced oxidation pilot plant, **CATADOX**. The process combines treatment by ozone, UV, hydrogen peroxide and proprietary catalyst to enable the industry to meet the ever-tightening environmental standards for wastewaters & gases.

The **CATADOX**, performs excellently in challenging applications such as micro-pollutant oxidation, non-biodegradable COD removal, TOC reduction, VOCs abatement, toxicity reduction, colour & odour removal.

Advanced oxidation processes are the most reliable means of meeting the new standards.

They offer substantial capital and operating cost savings compared with other conventional treatment processes.



“CATADOX” Process

CONCEPT & BENEFITS

The **CATDOX** system is specifically designed to efficiently treat a wide range of refractory organic pollutants, COD and TOC in water & gas effluents.

The process combines ozone, UV, H₂O₂ and proprietary catalyst.

By combining two oxidants, the oxidation potential will increase and the treatment can be more successful than a single oxidant.

The **CATADOX** system involves three main components for the effective generation & optimum use of hydroxyl free radicals for the enhanced oxidation of pollutants, COD and TOC:

- 1- UV-radiation,
- 2- ozone & hydrogen peroxide,
- 3- a proprietary catalyst.

The CATADOX process provides unique benefits:

- Significant cut down in ozone demand, hence smaller ozone generator
- Important reduction in oxygen and dry air requirements, hence lower power consumption
- Major reduction in cooling water capacity
- Reduction in plant size
- Higher flexibility in oxidants dosing vs incoming TOC or COD
- Better process performance and reliability
- Much lower overall power consumption
- no oxidant residual problems
- optimal combination of ozone , H₂O₂, UV available depending on water quality and requirements before discharge or reuse
- lower ozone, H₂O₂ and UV power requirements when compared to conventional H₂O₂/UV, O₃/UV and O₃/H₂O₂ AOP processes.

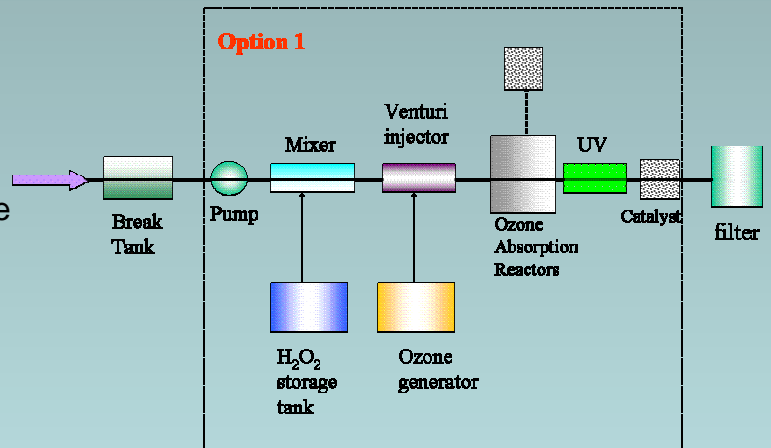

“CATADOX” PILOT

TECHNICAL SPECIFICATIONS

Wastewater feed flow rate range: 1-7 m³/h
 Waste gas flow rate range: 0-50 m³/min
 Ozone generation capacity: 0-240 g/h
 Ozone concentration range: 0 -150 ppm
 Hydrogen peroxide concentration range: 0-70 ppm
 UV oxidation power range: 0-1500 W
 Oxidation contact chamber: 5 – 20 min

Services requirements:

Mains power 400V, 50-60HZ, 3Phase
 Cooling water : by customer
 Oxygen (integrated)
 Hydrogen peroxide (integrated)
 pH adjustment (integrated)

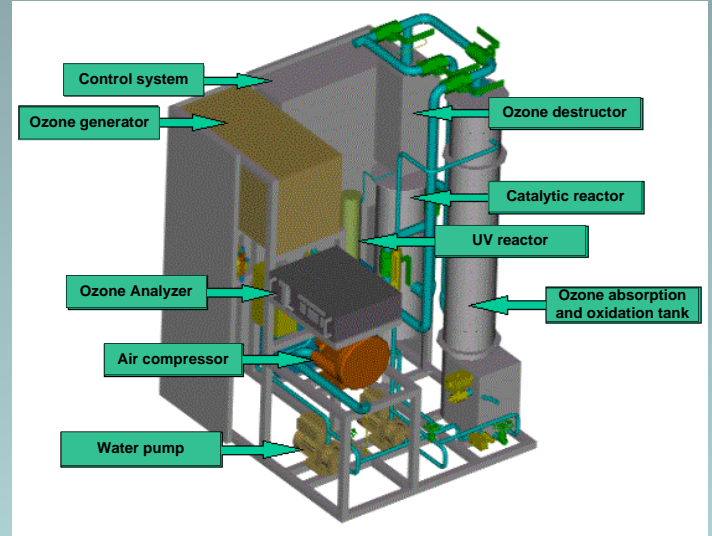

KEY BENEFITS:

- On-site destruction treatment technology
- No phase transfer required, thereby eliminating secondary handling
- Efficient for a wide range of contaminants types and concentrations including IPA, TMAH, NMP, DMSO, Glycols, VOCs, PAHs, PCBs, Alcohols, Ethers, TOC & COD and others..
- Low maintenance and operating requirements
- Quiet and unobtrusive equipment
- Safe and environmentally friendly

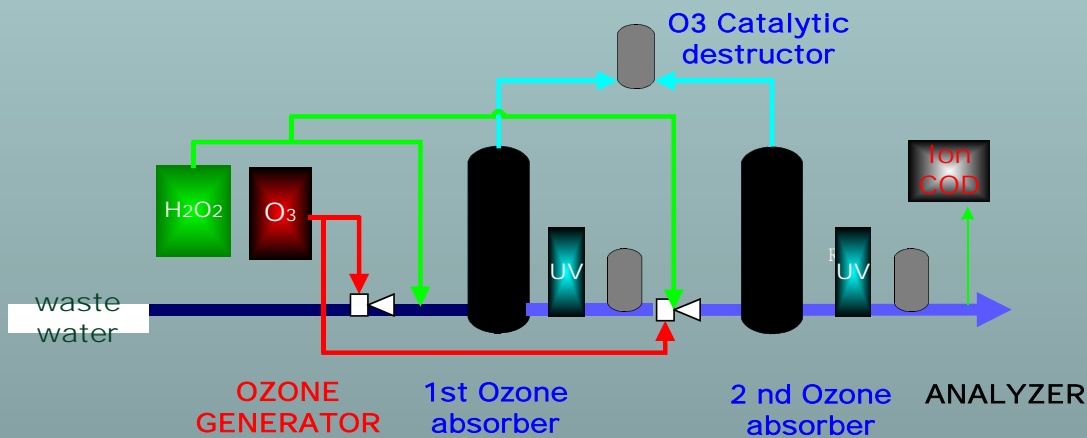

“CATADOX” PILOT

FEATURES:

- combination of advanced oxidation process (AOP) including ozone / UV / H₂O₂/Catalyst
- designed to mimic full scale plant operation
- mobile & self-contained plant
- high ozone dissolution and mass transfer performance
- pH correction of influent
- ozone generator
- integrated oxygen generating system
- vent ozone destruction
- dissolved ozone monitoring device



ADVANTAGES:

- allows experimentation with different loadings
- demonstrates effluent treatability
- enable you to conduct trials on your own site with the actual effluent to be treated
- establishes precise design parameters
- accurately predicts capital & operating costs

Recommendations:

If you are thinking of installing an on-site advanced oxidation plant for wastewater reclaim, it is sometimes necessary to carry out pilot studies to ensure that the correct design criteria are used for the full scale plant.

ESCO recommends that the pilot plant evaluation work is carried out for at least a week.

ADVANCED OXIDATION TECHNOLOGIES FOR WASTEWATER & GAS TREATMENT

What is Advanced Oxidation Process ?

Advanced oxidation processes (AOPs), uniting together ozone and properly designed ultraviolet systems, in conjunction with hydrogen peroxide, may offer a powerful water treatment solution for the reduction of undesirable organic compounds, COD and TOC.

The AOP process is successfully used to decompose many hazardous chemical compounds to acceptable levels, without producing additional hazardous by-products or sludge which require further handling.



The development of AOPs is an attempt to produce the non-selective and rapid hydroxyl radical OH° to oxidize pollutants. The most widely applied conventional AOP systems has been the $\text{H}_2\text{O}_2/\text{UV}$, O_3/UV , $\text{H}_2\text{O}_2/\text{O}_3$ and $\text{H}_2\text{O}_2/\text{O}_3/\text{UV}$ processes. Oxidizing agents, Hydrogen peroxide and Ozone are added to the contaminated water and is activated by the UV light to form oxidizing species called hydroxyl radicals, via:



The hydroxyl radical reacts with the dissolved contaminants, initiating a rapid cascade of oxidation reactions that ultimately fully oxidize (mineralizes) the contaminants.

The most recent generation in advanced oxidation technologies is the CATADOX process, developed, designed and tested by ESCO.

ADVANCED OXIDATION TECHNOLOGIES APPLICATIONS

Applications ?

Advanced Oxidation Processes have a wide range of applications, mainly for the oxidation of refractory compounds, TOC & COD reduction in:

- . water reclaim / reuse / recycling
- . drinking water supplies
- . industrial & municipal wastewaters
- . process water, ultra-pure water
- . electronic & pharmaceutical industries
- . mineral water and beverage industries
- . public and private swimming pools,
- . medicinal baths, sanatoriums, hospitals
- . cooling water systems
- . bottling & rinsing plants
- . fish hatcheries and farm
- . Gas effluent treatment

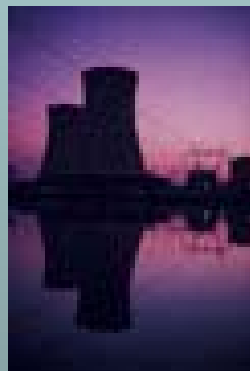
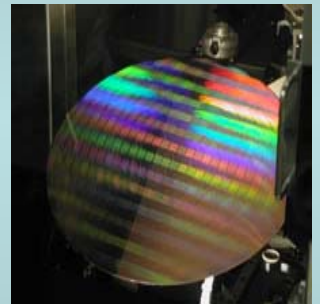

Want to know more ?

AOP and CATADOX Systems are available from our partners

ozono elettronica internazionale

Via Pavia, 28 -20053 Muggiò (Milano)- Italy

Tel. 39 039 2782703 - Fax. 39 039 2782798

Email: ozono@ozono.it - Website: www.ozono.it

Ozone & AOP knowledge-based solutions providers