

OS Series

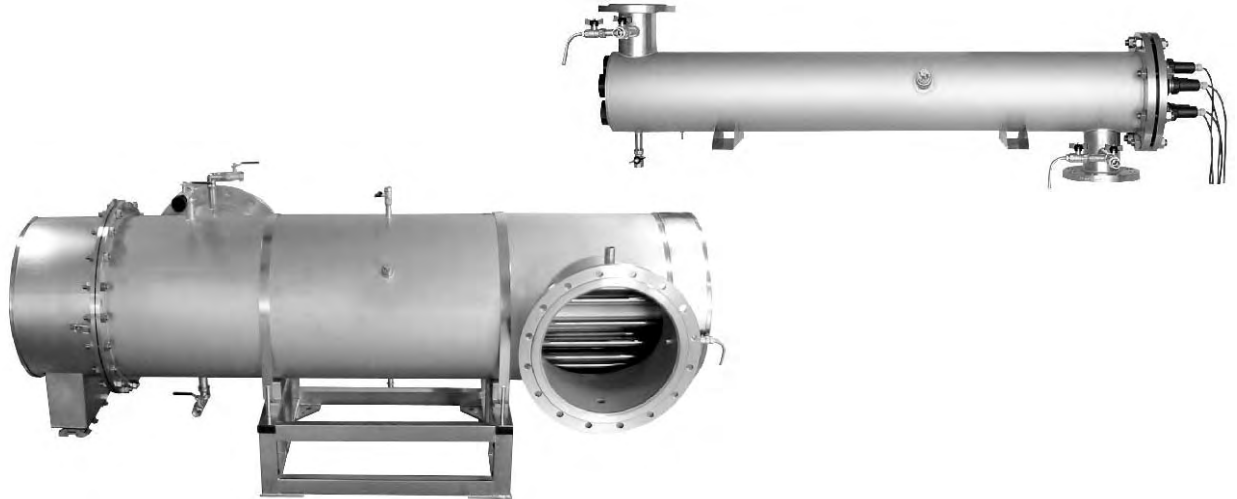

Series description

LIT OS systems are applied to wastewater disinfection. The models of this series were developed on base of high-efficiency low-pressure amalgam lamps and have all components integrated in a compact stainless steel chamber and separate electrical cabinet. OS units were designed and are manufactured according to international standards for UV disinfection of wastewater water.

Type	Number of UV lamps	Nominal flow rate* (m ³ /h)	Power consumption (kW)	Connection flanges	Control cabinet type	Cleaning system type
OS-1A	1	13	0,28	DN 50	Type 2	WB-2
OS-2A	2	25	0,56	DN 50	Type 2	WB-2
OS-4A	4	70	1,12	DN 100	Type 2	WB-5C
OS-5A	5	86	1,4	DN 100	Type 2	WB-5C
OS-7A	7	130	2	DN 100	Type 3	WB-5C
OS-12A	12	220	3,2	DN 250	Type 3	WB-5C
OS-18A	18	329	5	DN 300	Type 3	WB-5C
OS-36A	36	661	10	DN 400	Type 3	WB-5C

* 300 J/m² at 70% water transmittance at the end of lamp life.

Application

LIT OS series units are applied for:

- municipal and industrial wastewater disinfection;
- process water and industrial recirculated water;
- irrigation water;
- sea- water.
-

Advantages

- reliable disinfection with low energy consumption;
- high-power amalgam lamp technology;
- compact design in combination with large flow capacities;
- reliable operation and long service life;
- easy operation and maintenance.

OS System Description and Components

Principle of operation

UV reactor of OS units has a longitudinal geometry with side inlet/outlet flanges. Water enters the chamber and is exposed to germicidal radiation destructive for bacteria and viruses. UV lamps are isolated from treated water by special quartz sleeves made of high quality fused quartz with high transmission coefficient for ultraviolet radiation (95%). After UV treatment water doesn't contain microorganisms dangerous to health and is instantly ready for use.

UV Dose

OS units ensure high UV dose in a wide range of water transmission values. The minimal required dose is guaranteed over all time of lamps life taking into account lamps aging.

UV Lamps

All units are equipped with modern, industrially manufactured amalgam lamps having long service life and enhanced UV-C output. Low depreciation of UV-radiation intensity at the end of lamp life guarantees effective disinfection during the whole operation period of OS units.

UV sensor

According to Russian Hygiene Governmental Authority all OS units are equipped with UV-radiation intensity sensor. It allows to continuously monitor UV dose and generate alarm signals when UV dose drops lower than necessary level.

Control Cabinet

Proper operation of UV system is provided through control cabinet according to the table above. LIT OS systems are supplied with two types of control cabinet described below.

Cleaning System

Standard delivery package of all LIT OS units includes a special chemical cleaning system for regular cleaning of disinfection chamber and quartz sleeves. Chemical cleaning system consists of stainless steel tank, water pump and set of pipes. The tank is used for preparation of cleaning solution. The water pump provides circulation of water mixed with cleaning solution through the chamber. The 0.2 % aqueous solution of citric or oxalic acid is used for periodical cleaning (once 2-3 months) of disinfection chamber. Chemical cleaning method provides effective removal of fouling from quartz sleeves and inner walls of disinfection chamber and requires minimum labour and material resources.

OS-1A UV System

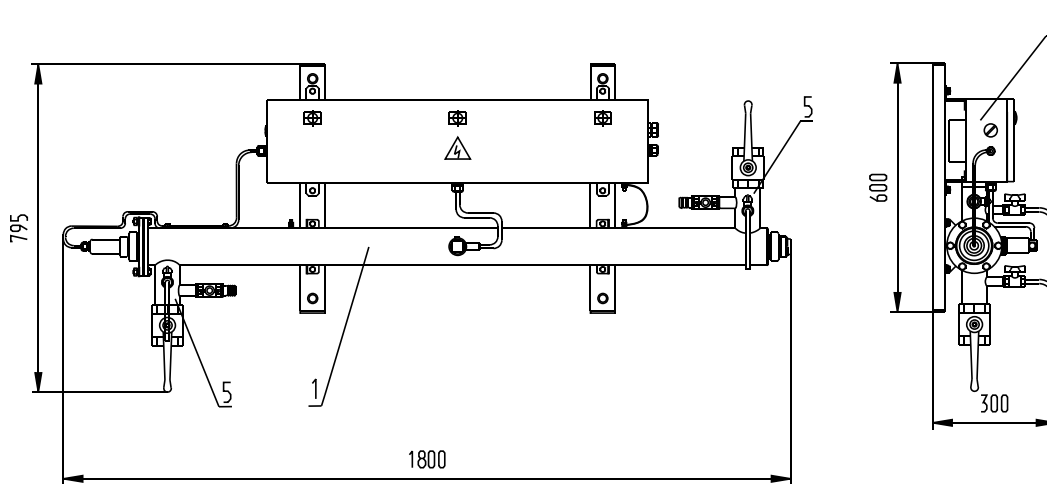

View without ballast cabinet

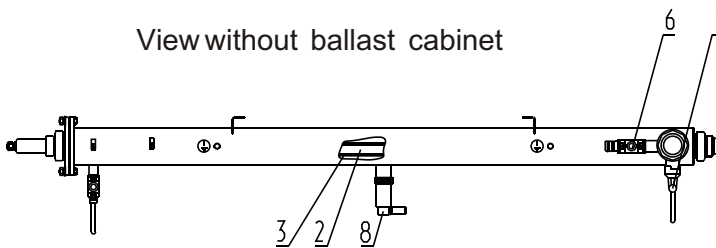

- 1 - UV chamber,
- 2 - UV lamp,
- 3 - quartz sleeve,
- 4 - ballast cabinet,
- 5 - input/output flanges (2"),
- 6 - cleaning valves (3/4"),
- 7 - sampling valves ,
- 8 - UV sensor.

Technical specification

UV-unit type	OS-1A
Nominal flow rate (300 J/m ² at 70% water transmittance)	13 m ³ /h
Number of UV-lamps per unit	1
UV-lamp type	DB-300
Guaranteed lifetime of the lamp	12 000 hours
UV chamber material	Stainless steel 304/316*
Chamber volume	7,5 liters
Maximum operating pressure	8 bar
UV chamber protection class	IP 65
Dry chamber weight	37 kg
Power consumption	220 V / 50-60 Hz / 0,28 kW
Power factor	>0,96
Connection	DN 50
Water temperature	1 C – 30 C
Head loss	See diagram below

* upon customer's request

OS-2A UV System

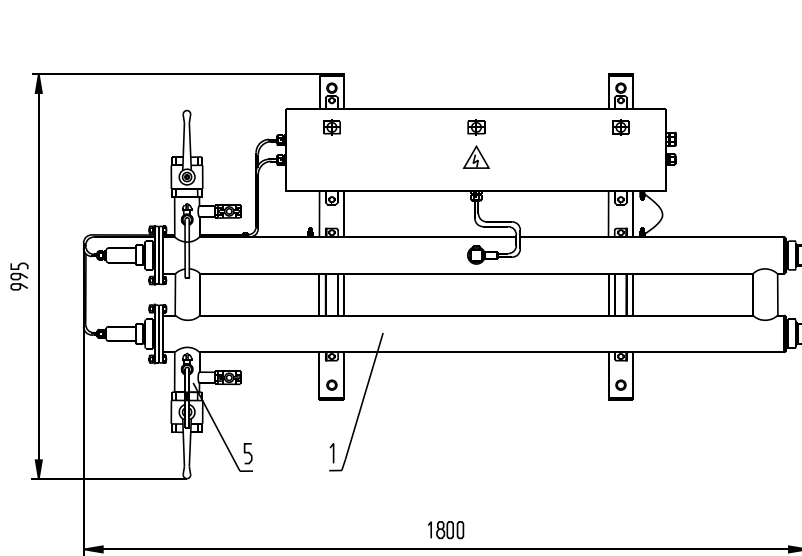

View without ballast cabinet

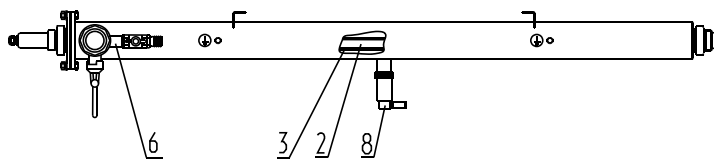
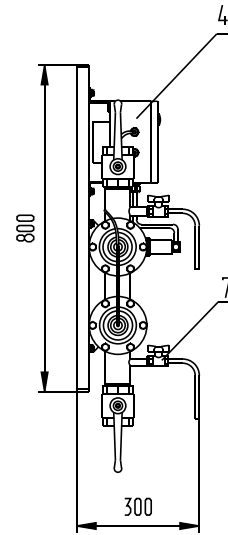

- 1 - UV chamber,
- 2 - UV lamp,
- 3 - quartz sleeve,
- 4 - ballast cabinet,
- 5 - input/output flanges (2"),
- 6 - cleaning valves (3/4"),
- 7 - sampling valves ,
- 8 - UV sensor.

Technical specification

UV-unit type	OS-2A
Nominal flow rate (300 J/m ² at 70% water transmittance)	25 m ³ /h
Number of UV-lamps per unit	2
UV-lamp type	DB-300
Guaranteed lifetime of the lamp	12 000 hours
UV chamber material	Stainless steel 304/316*
Chamber volume	15 liters
Maximum operating pressure	8 bar
UV chamber protection class	IP 65
Dry chamber weight	60 kg
Power consumption	220 V / 50-60 Hz / 0.56 kW
Power factor	>0,96
Connection	DN 50
Water temperature	1 C – 30 C
Head loss	See diagram below

* upon customer`s request

OS-4A UV System

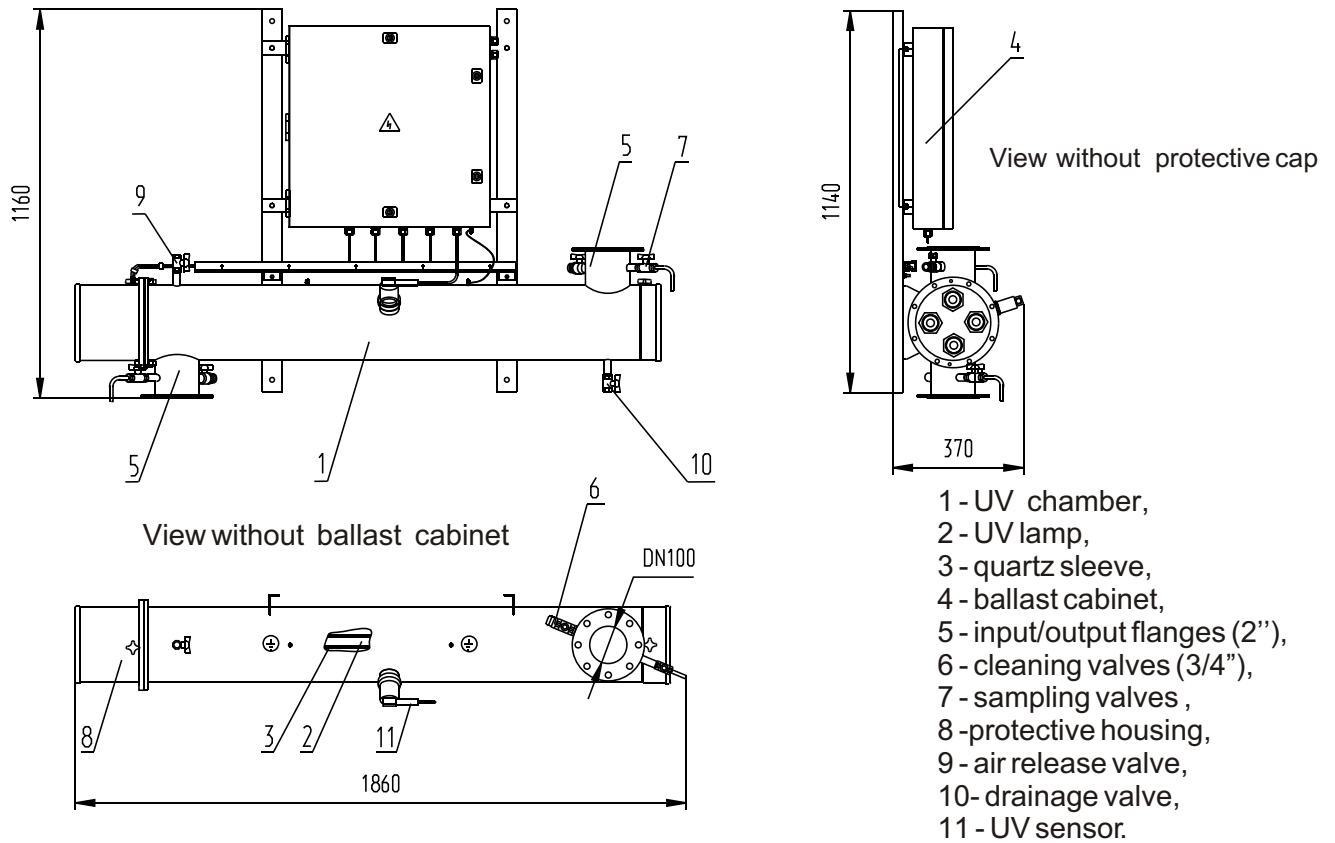

Technical specification

UV-unit type	OS-4A
Nominal flow rate (300 J/m ² at 70% water transmittance)	70 m ³ /h
Number of UV-lamps per unit	4
UV-lamp type	DB-300
Guaranteed lifetime of the lamp	12 000 hours
UV chamber material	Stainless steel 304/316*
Chamber volume	61 liters
Maximum operating pressure	8 bar
UV chamber protection class	IP 65
Dry chamber weight	74 kg
Power consumption	220 V / 50-60 Hz / 1,12 kW
Power factor	>0,96
Connection	DN 100
Water temperature	1 C – 30 C
Head loss	See diagram below

* upon customer`s request

OS-5A UV System

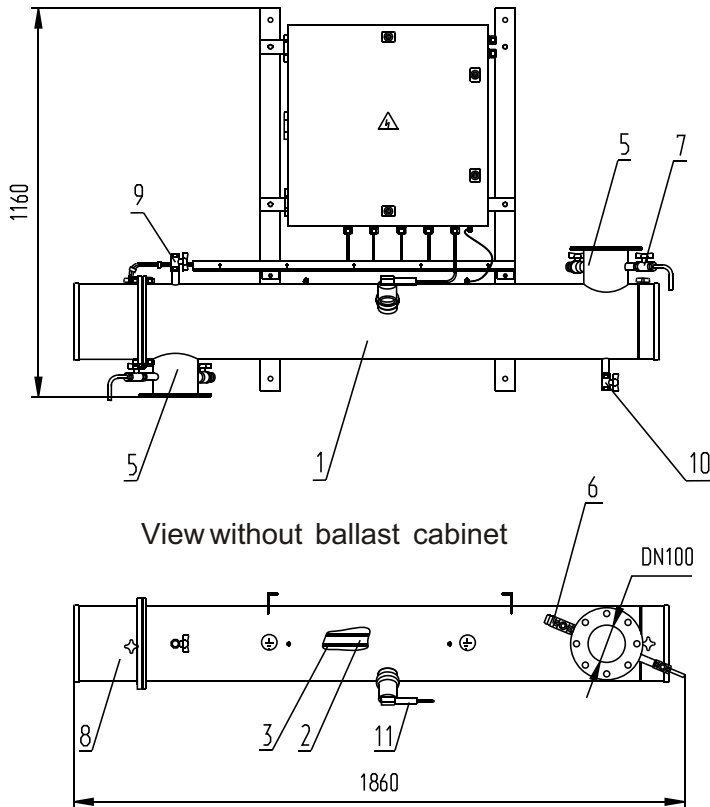

View without protective cap

View without ballast cabinet

- 1 - UV chamber,
- 2 - UV lamp,
- 3 - quartz sleeve,
- 4 - ballast cabinet,
- 5 - input/output flanges,
- 6 - cleaning valves (3/4"),
- 7 - sampling valves,
- 8 - protective cap,
- 9 - air release valve,
- 10 - drainage valve,
- 11 - UV sensor.

Technical specification

UV-unit type	OS-5A
Nominal flow rate (300 J/m ² at 70% water transmittance)	86 m ³ /h
Number of UV-lamps per unit	5
UV-lamp type	DB-300
Guaranteed lifetime of the lamp	12 000 hours
UV chamber material	Stainless steel 304/316*
Chamber volume	60 liters
Maximum operating pressure	8 bar
UV chamber protection class	IP 65
Dry chamber weight	77 kg
Power consumption	220 V / 50-60 Hz / 1,4 kW
Power factor	>0,96
Connection	DN 100
Water temperature	1 C – 30 C
Head loss	See diagram below

* upon customer's request

OS-7A UV System

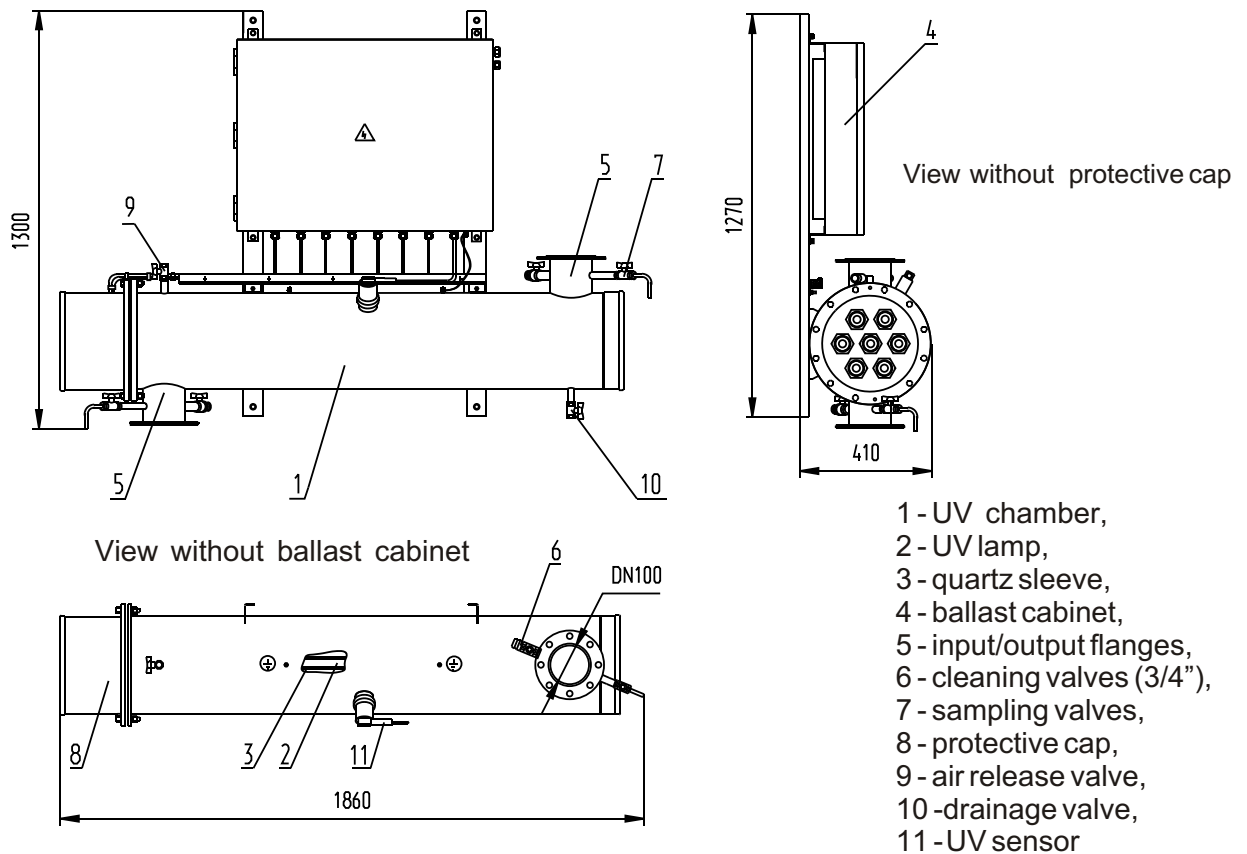

Technical specification

UV-unit type	OS-7A
Nominal flow rate (300 J/m ² at 70% water transmittance)	130 m ³ /h
Number of UV-lamps per unit	7
UV-lamp type	DB-300
Guaranteed lifetime of the lamp	12 000 hours
UV chamber material	Stainless steel 304/316*
Chamber volume	100 liters
Maximum operating pressure	8 bar
UV chamber protection class	IP 65
Dry chamber weight	110 kg
Power consumption	220 V / 50-60 Hz / 2 kW
Power factor	>0,96
Flanges diameter	DN 100
Water temperature	1 C – 30 C
Head loss	See diagram below

* upon customer`s request

OS-12A UV System

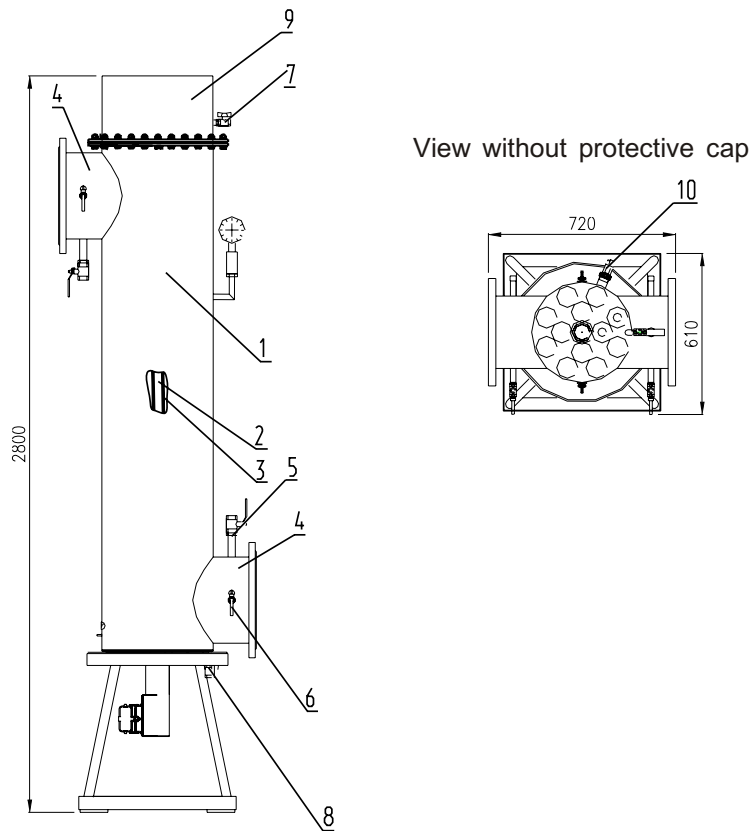

- 1 - UV chamber,
- 2 - UV lamp,
- 3 - quartz sleeve,
- 4 - input/output flanges,
- 5 - cleaning valves (3/4"),
- 6 - sampling valves,
- 7 - air release valve,
- 8 - drainage valve,
- 9 - protective cap,
- 10- UV sensor.

Technical specification

Nominal flow rate (300 J/m ² at 70% water transmittance)	220 m ³ /h
Number of UV-lamps per unit	12
UV-lamp type	DB-300
Guaranteed lifetime of the lamp	12 000 hours
UV chamber material	Stainless steel 304/316*
Chamber volume	220 liters
Maximum operating pressure	8 bar
UV chamber protection class	IP 65
Dry chamber weight	285 kg
Power consumption	220 V / 50 - 60 Hz / 3,2 kW
Power factor	>0,96
Connection	DN 250
Water temperature	1 C – 30 C
Head loss	See diagram below

* upon customer`s request

OS-18A UV System

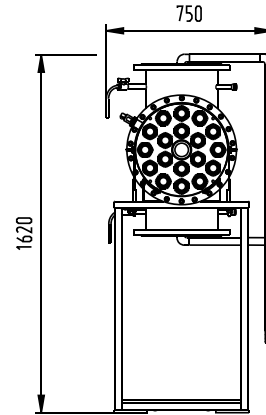
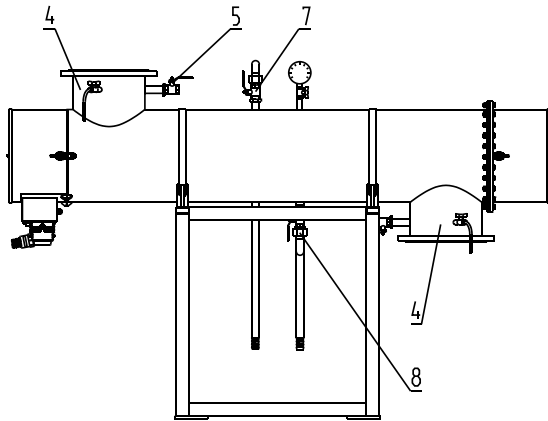

View without protective cap

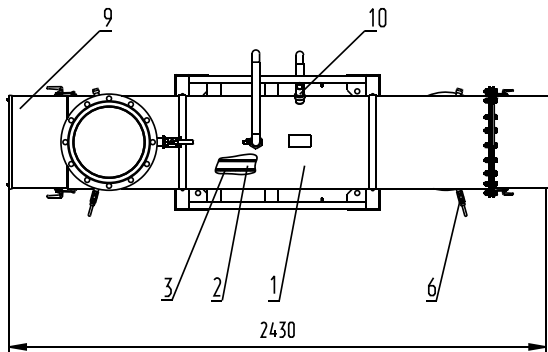

- 1 - UV chamber,
- 2 - UV lamp,
- 3 - quartz sleeve,
- 4 - input/output flanges,
- 5 - cleaning valves (3/4"),
- 6 - sampling valves,
- 7 - air release valve,
- 8 - drainage valve,
- 9 - protective cap,
- 10 - UV sensor.

Technical specification

UV-unit type	OS-18A
Nominal flow rate (300 J/m ² at 70% water transmittance)	329 m ³ /h
Number of UV-lamps per unit	18
UV-lamp type	DB-300
Guaranteed lifetime of the lamp	12 000 hours
UV chamber material	Stainless steel 304/316*
Chamber volume	263 liters
Maximum operating pressure	8 bar
UV chamber protection class	IP 65
Dry chamber weight	295 kg
Power consumption	220 V / 50 - 60 Hz / 5 kW
Power factor	>0,96
Connection	DN 300
Water temperature	1 C – 30 C
Head loss	See diagram below

* upon customer`s request

OS-36A UV System

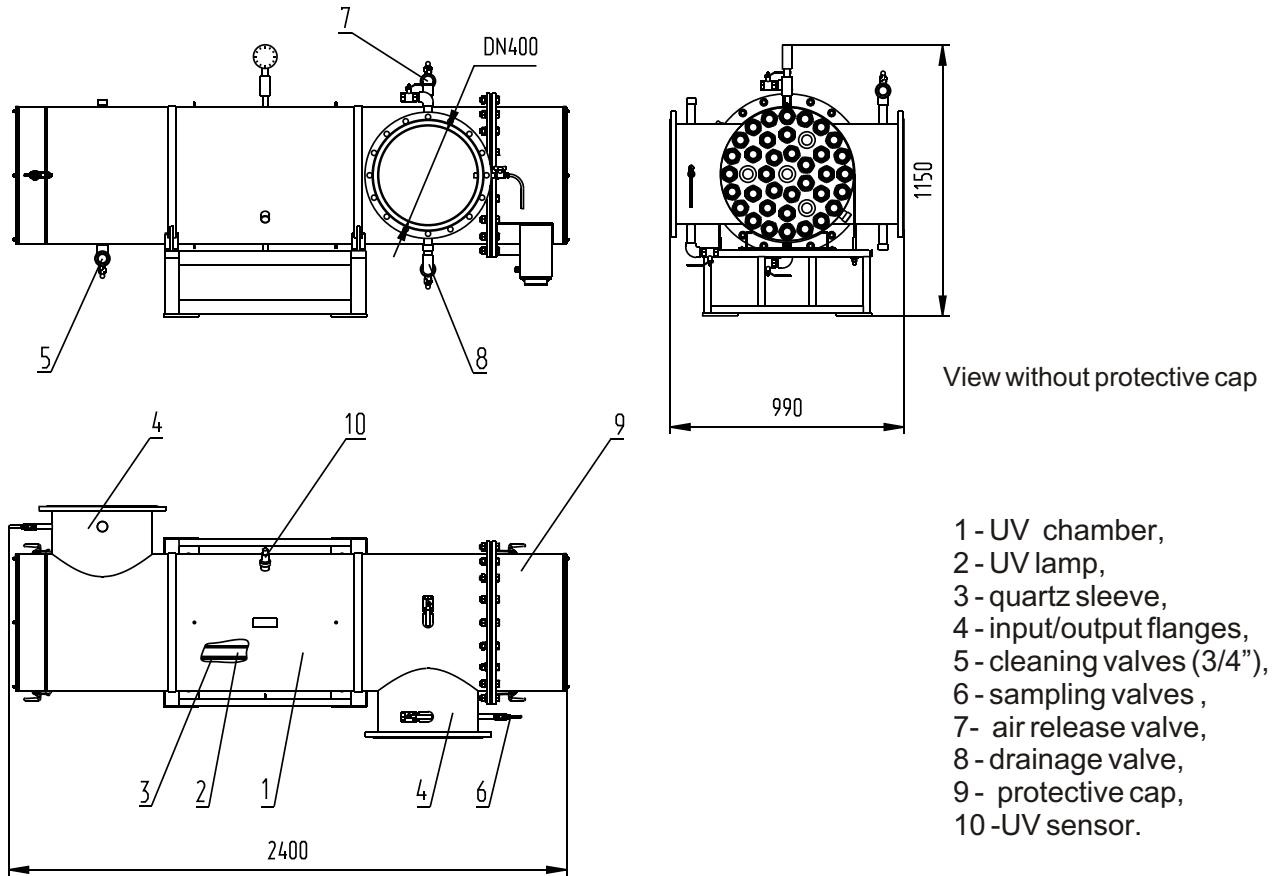

Technical specification

UV-unit type	OS-36A
Nominal flow rate (300 J/m ² at 70% water transmittance)	661 m ³ /hr
Number of UV-lamps per unit	36
UV-lamp type	DB-300
Guaranteed lifetime of the lamp	12 000 hours
UV chamber material	Stainless steel 304/316*
Chamber volume	465 liters
Maximum operating pressure	8 bar
UV chamber protection class	IP 65
Dry chamber weight	390 kg
Power consumption	220 V / 50-60 Hz / 10 kW
Power factor	>0,96
Connection	DN 400
Water temperature	1 C – 30 C
Head loss	See diagram below

* upon customer's request

Example of typical installation of OS plants

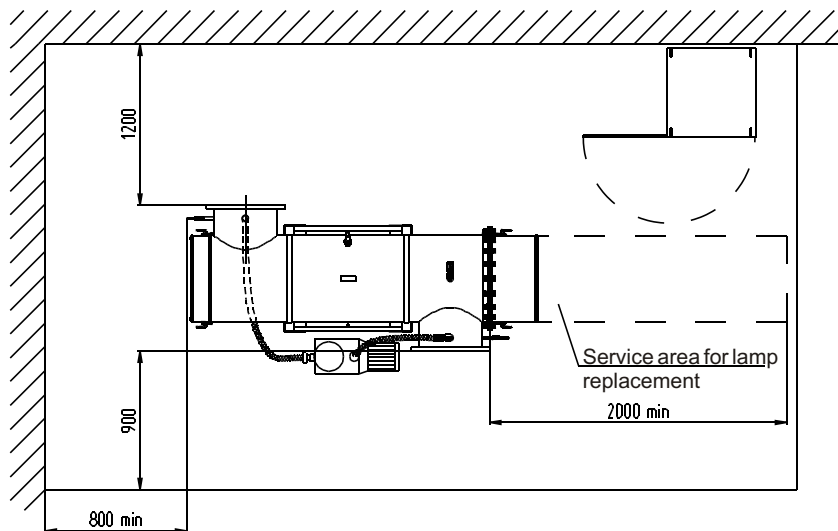
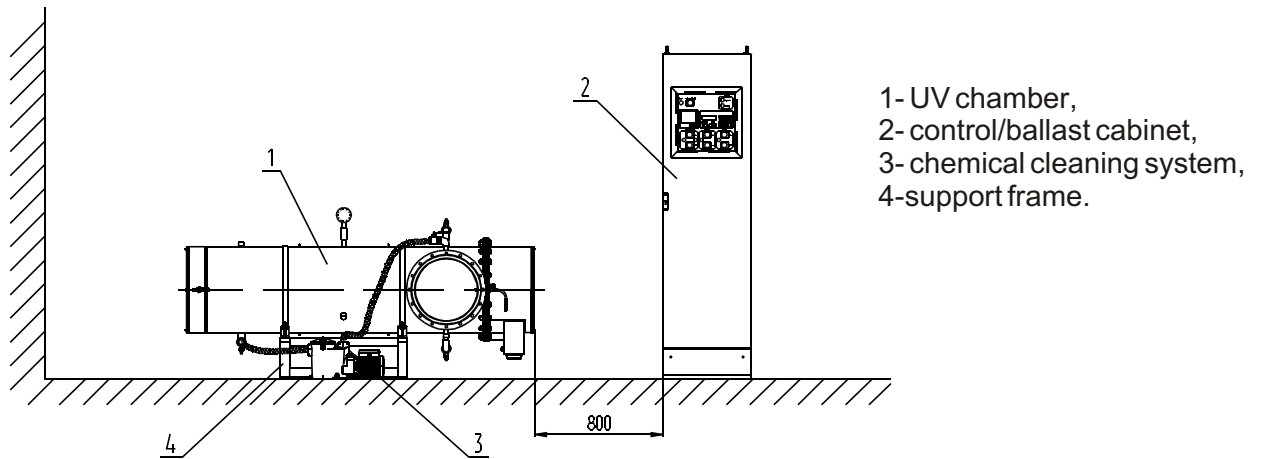

Installation instructions

OS units must be installed according to the instructions provided in Installation, Operating and Maintenance Manual supplied with unit.

Water pressure in connecting pipes should not exceed 8 kg/cm^2 (8 Bar).

It is recommended to equip water supply pipe with flow-meter and flow regulating device.

Sufficient space has to be allocated to install the components of the UV system and provide free access to them during maintenance and repair works. Special service zones should be provided as it is indicated in assembly drawing.

The control cabinet should be fixed on the wall or frame in easily accessible place convenient for observation of the front panel.

In the operating area temperature must be kept within the range of $+1\text{C}^\circ + 35\text{C}^\circ$, humidity - not more than 80%.

Control cabinet. TYPE 2

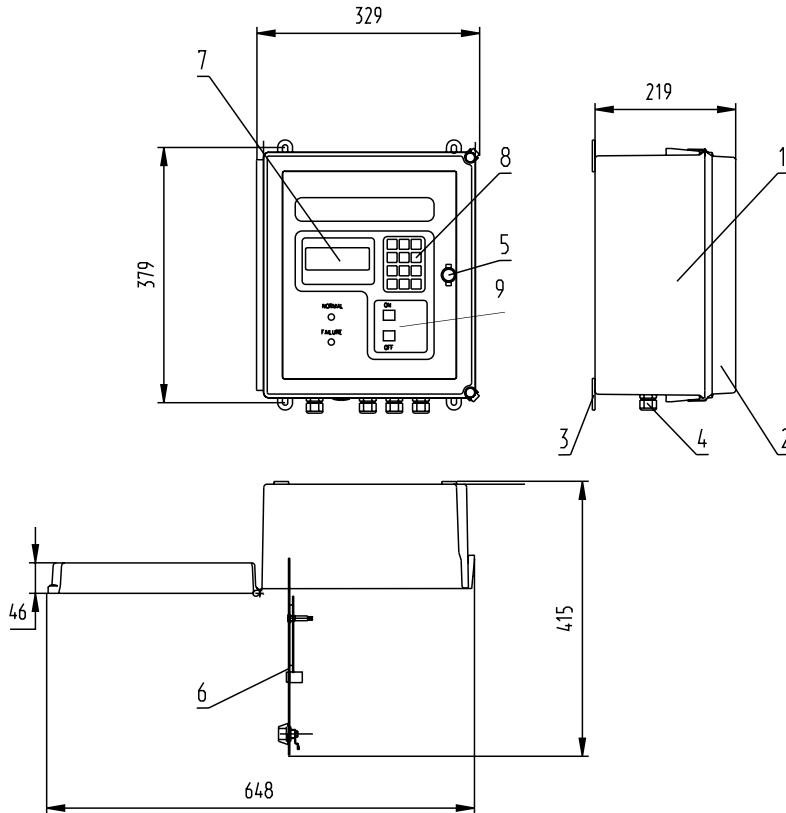

General description

Control and monitoring of UV system operation is performed through control cabinet. LIT control cabinet (type 2) consists of plastic (or optional stainless steel) housing with glass front door. Through the door one can see folding front panel that serves for monitoring and control. There are liquid crystal display, keyboard, system on/off button and light indicators placed on the panel.

- 1 - housing,
- 2 - glass door,
- 3 - bracing,
- 4 - hermetic lead-in,
- 5 - latch,
- 6 - bolding front panel,
- 7 - LC Display,
- 8 - keyboard,
- 9 - on/off button.

Control capability

1. Local switching on/off the UV plant

Applicable UV units	Electricity requirements	Weight	Dimensions, mm	Protection class
OS-1A OS-2A OS-4A OS-5A OS-7A	220V / 50 - 60Hz	10 kg	329 x 379 x 219	IP 65

Monitoring capability

Local:

1. UV system on/off status
2. Operation status (normal operation, warning, failure)
3. UV intensity in the chamber (W/m² or %)
4. Number of on/off cycles
5. Total operation time of UV system
6. Total operation time of UV lamps
7. Status of each lamp
8. Critical temperature in ballast cabinet
9. Critical temperature of treated water

Remote:

1. UV system on/off status (through dry contacts)
2. Operation status: normal operation, warning, failure (through dry contact)
3. UV intensity in the chamber (through 4...20 mA signal)

Control cabinet. TYPE 3

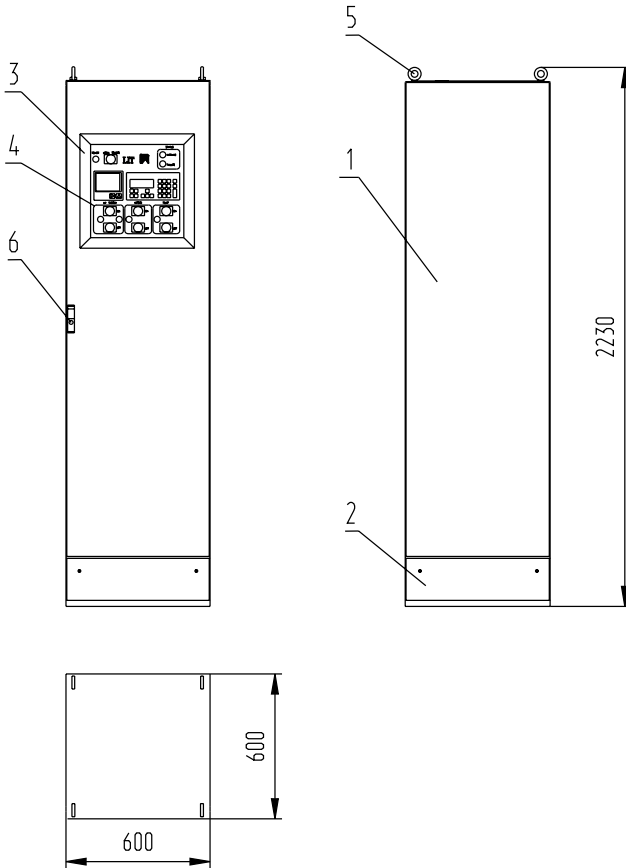

General description

Control and monitoring of UV system operation is performed through control cabinet. LIT control cabinet (type 3) consists of painted steel (or optional stainless steel) housing with front door. On the front door there is a sighting window made of glass. Behind the window there is front panel that serves for monitoring and control. The liquid crystal display, keyboard, control buttons and light indicators are placed on the panel. The electronic ballasts are mounted inside the housing.

- 1 - housing,
- 2 - base,
- 3 - glass window,
- 4 - front panel,
- 5 - eye-bolt,
- 6 - latch.

Applicable UV units	Electricity requirements	Weight	Dimensions, mm	Protection class
OS-12A OS-18A OS-36A	220 V / 50 - 60Hz	Max 200 kg	600 x 2230 x 600	IP 54

There are two main operating modes of the control cabinet:

- local - through keyboard and buttons on the panel of the cabinet
- remote control from central control room of water treatment plant - through dry contacts or RS-485 serial bus

Monitoring capability

(in both local and remote modes):

1. UV system on/off status
2. Operation status (normal operation, warning, failure)
3. UV intensity in the chamber (W/m² or %)
4. Number of on/off cycles
5. Total operation time of UV system
6. Total operation time of UV lamps
7. Status of each lamp
8. Critical temperature in control cabinet
9. Critical temperature of treated water

Control capability

1. Local switching on/off the UV plant
2. Local switching on/off the chemical cleaning pump
3. Remote switching on/off the UV plant

Chemical cleaning system WB-2

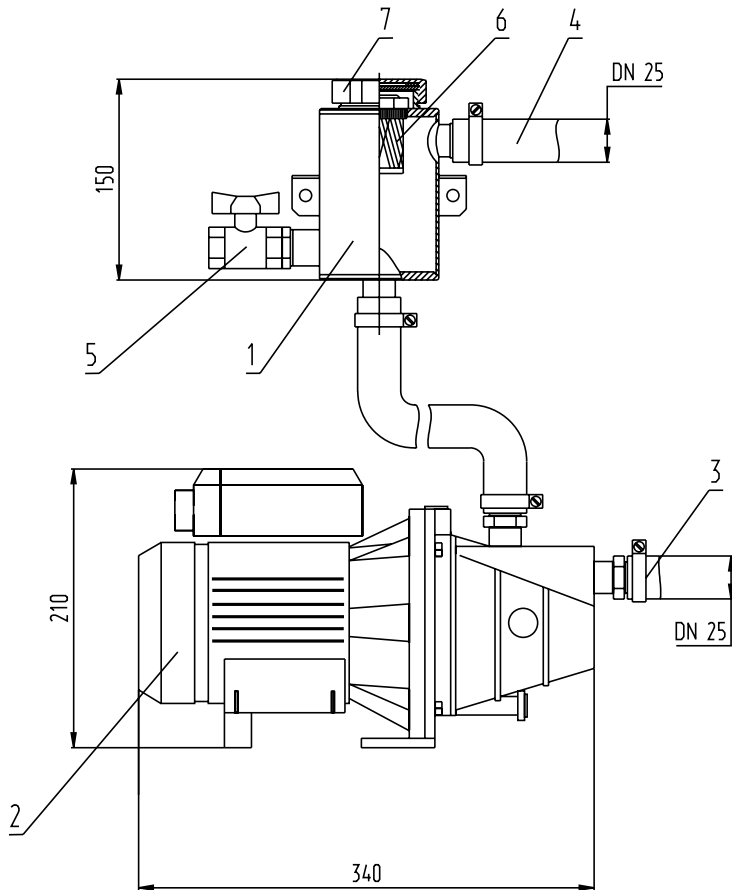

General description

The chemical cleaning system consists of circulation pump, stainless steel tank for preparation of cleaning solution, pipes and valves. The cleaning tank and pump are connected with flexible pipe. Cleaning is carried out with oxalic (or citric) acid, which is supplied in the form of powder and dissolved in the tank before cleaning. When the pump is on the water mixes with cleaning solution and circulates through UV chamber. After cleaning the water is removed out of the chamber through water discharge tap mounted on the chamber.

- 1- tank for cleaning solution,
- 2- pump,
- 3- inlet connection,
- 4- outlet connection,
- 5- drain valve,
- 6- reservoir for cleaning agent,
- 7- tank cap.

Technical specification

System type	WB-2
Cleaning tank material	Stainless steel 304/316*
Cleaning tank volume, l	0,7
Connection pipes	DN 25
Cleaning agent	Oxalic acid
Electricity requirements	220 V, 50 - 60 Hz
Power consumption, kW	0,72
Overall dimensions (length height width), mm	
Electric pump	340 210 185
Tank	210 150 112
Weight, kg:	
Electric pump	7
Tank	2

* upon customer`s request

Chemical cleaning system WB-5C

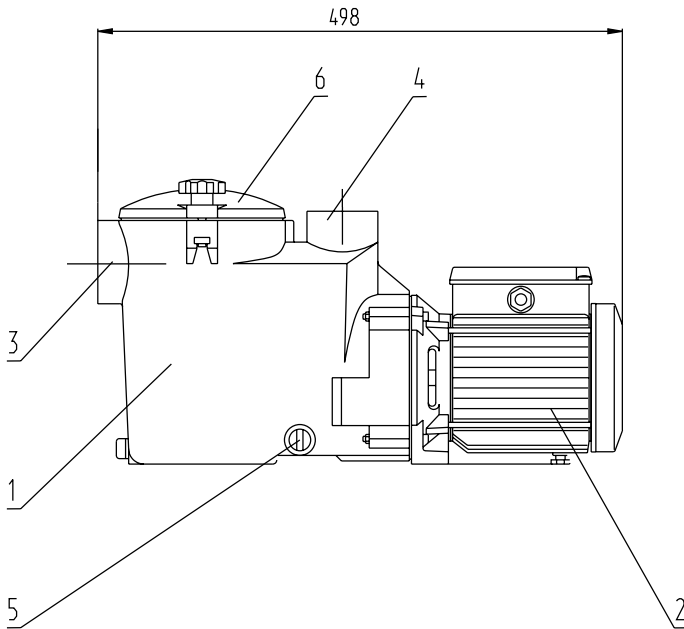

- 1 - tank for cleaning solution,
- 2 - pump,
- 3 - inlet connection,
- 4 - outlet connection,
- 5 - seal,
- 6 - tank cap.

General description

The chemical cleaning system consists of circulation pump with embedded stainless steel tank for preparation of cleaning solution, pipes and valves. Cleaning is carried out with oxalic (or citric) acid, which is supplied in the form of powder and dissolved in the tank before cleaning. When the pump is on the water mixes with cleaning solution and circulates through UV chamber. After cleaning the water is removed out of the chamber through water discharge tap mounted on the chamber.

Technical specification

System type	WB-5C
Cleaning tank material	Plastic armored with glass fiber PRO-GF30
Cleaning tank volume, l	5
Connection pipes	DN 25
Cleaning agent	Oxalic acid
Electricity requirements	220 V, 50 - 60 Hz
Power consumption, kW	0,72
Overall dimensions (length height width), mm	498 270 215
Weight, kg	9

Hydraulic Parameters of OS plants

Flow diagram for OS -A units (UV Doze = 300 J/m²)

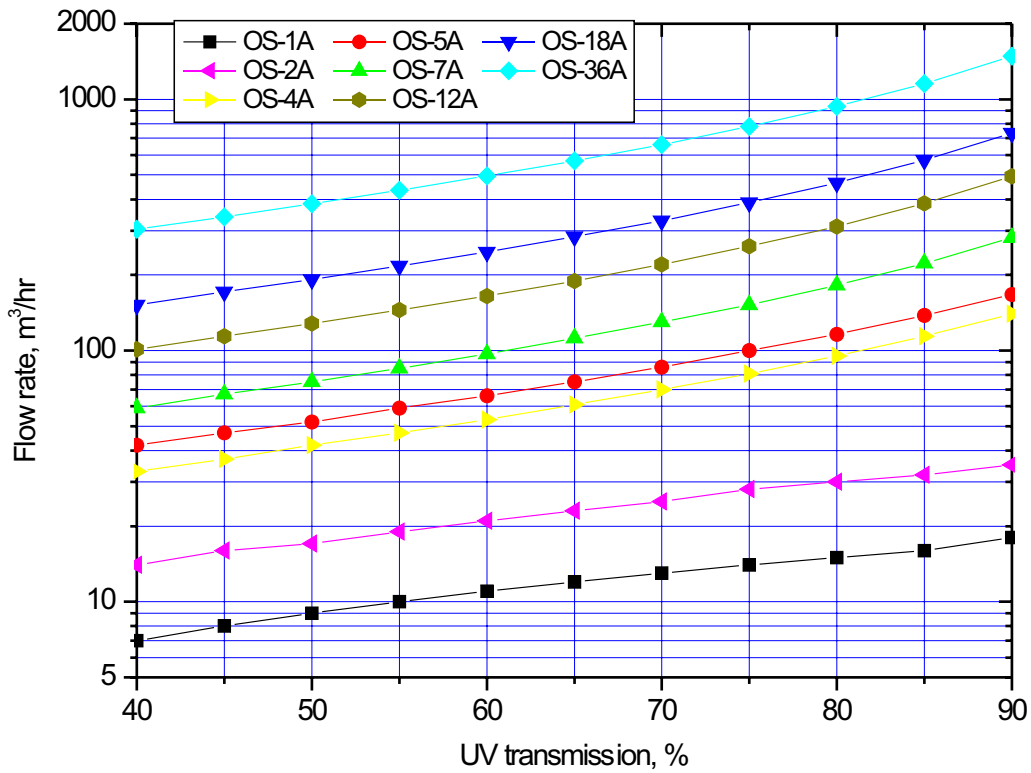

Head loss diagram for OS-A units

